

Part III

Reel Outline Drawing

Table of Contents

Part III - Reel Outline Drawing

<u>REEL OUTLINE DRAWING</u>	-----	III-1
<u>TO-92 TAPING SPEC. DRAWING</u>	-----	III-1

Part III Reel Outline Drawing

(unit : mm)

● REEL OUTLINE DRAWING

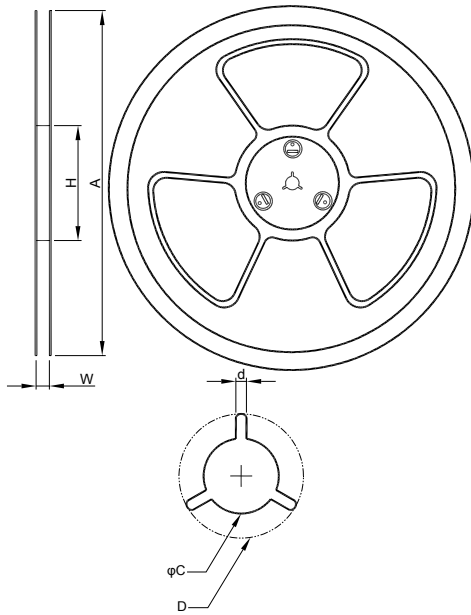

Package Type	A	H	W	C	d	D
TO-263-3L TO-263-5L	330±2	60 MIN.	24.4 ^{+2.0} _{-0.0}	13.0 ^{+0.5} _{-0.2}	1.5 MIN.	20.2 MIN.
TO-252-3L TO-252-5L SOP-14(150mil) SOP-16(150mil) SOP-16W(300mil)	330±2	50 MIN.	16.4 ^{+2.0} _{-0.0}	13.0 ^{+0.5} _{-0.2}	1.5 MIN.	20.2 MIN.
SOP-8 TSSOP-16 MSOP-8 MSOP-10 SOT-223 QFN 3x3 QFN 4x4 DFN 3x3	330±2	50 MIN.	12.4 ^{+2.0} _{-0.0}	13.0 ^{+0.5} _{-0.2}	1.5 MIN.	20.2 MIN.
SOT-89-3L SOT-89-5L	178±2	50 MIN.	12.4 ^{+2.0} _{-0.0}	13.0 ^{+0.5} _{-0.2}	1.5 MIN.	20.2 MIN.
SOT-143 SOT-23-x TSOT-23-x SC-70 SC-82 DFN 2x2	178±2	50 MIN.	8.4 ^{+2.0} _{-0.0}	13.0 ^{+0.5} _{-0.2}	1.5 MIN.	20.2 MIN.

Note: Refer to EIA-481-B

● TO-92 TAPING SPEC. DRAWING

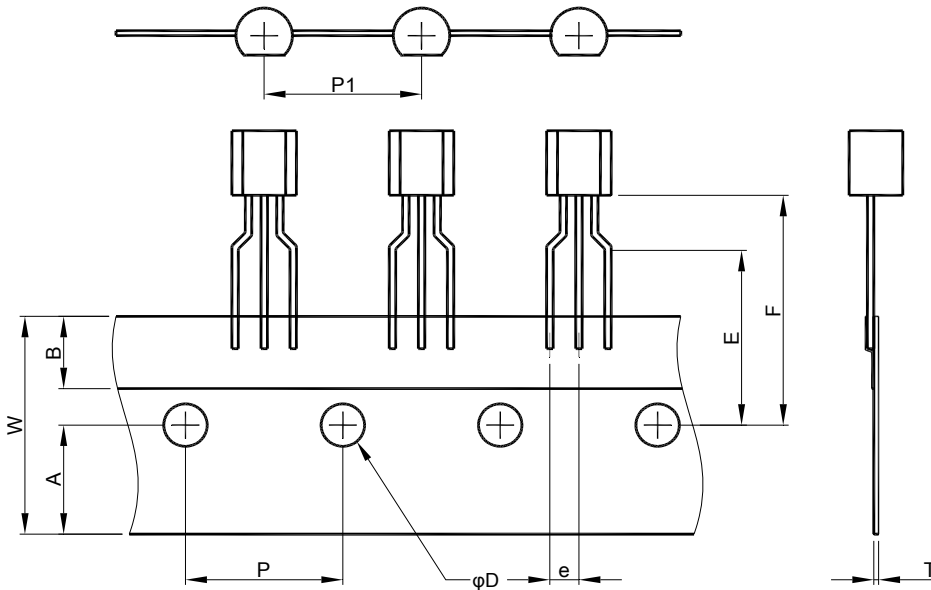

SYMBOL	W	A	B	E	F
SPEC.	18.0±0.2	9.0±0.2	6.0±0.20	16.0±0.5	19.0±0.5
SYMBOL	P	P1	D	e	T
SPEC.	12.7 BSC	12.7 BSC	4.0±0.2	2.5 BSC	0.6±0.1